

**AURA**®

**fireball**

**OWNER'S**

**MANUAL**



**FIREBALL-623**

6.5" 3-Way Coaxial Speaker

**WARNING!**

PLEASE READ CAREFULLY BEFORE USING

# YOUR SPEAKER

---

## Dear Customer,

Congratulations on purchasing our Aura Speaker.

This product has been designed and manufactured to Aura's exacting standards to ensure many years of audio enjoyment. For the best performance, we recommend that you have your Aura product installed by an authorized Aura dealer.

If you would like to install this product on your own, we recommend for you to go through this manual to familiarize yourself with all the installation requirements and procedures.

If you encounter any issues or if you have any questions on the operation of this product, please contact your nearest authorized Aura dealer for assistance, or you may also contact us through our website or social media channels.

## Installation of Your Product

In today's modern vehicles, it is very easy to cause damage to existing systems through improper installation. Please follow and scrutinize all wiring diagrams to ensure that you have connected everything in its proper place.

If you find yourself uncomfortable or unfamiliar with understanding the wiring and installation diagrams or testing instructions, do contact your nearest Aura dealer to perform the installation for you.

## Safety Warnings and Considerations

- Clean only with a dry cloth or other similar materials.
- Install your product in a dry, well-ventilated location that does not interfere with your vehicle's safety equipment.
- Do not block any ventilation openings when installing this product.
- Do not mount the product in the engine compartment of your vehicle or in any areas of extreme heat such as mufflers, silencers, exhaust pipes or other heat producing apparatus.
- Securely mount the product so that it does not come loose in the event of a collision or as a result of repeated vibrations that might occur during normal operation.
- Installation of the apparatus must be done with great care to prevent damage to your vehicle's fuel lines, power, and other electrical wiring, hydraulic brake lines, and other systems. If possible, always visit your nearest Aura dealer to perform the installation.
- Do not run any wiring outside or underneath the vehicle. Keep all wires inside the vehicle.
- Take the necessary precautions when making connections to the vehicle's battery to avoid any potential shock.
- Protect all system wires from sharp edges by carefully routing them, always use rubber grommets to protect wiring and cables whenever you are installing them through metal openings.
- Secure all wiring using cable ties or wire clamps to protect them from moving parts and sharp edges.
- This apparatus shall not be exposed to dripping or splashing, and no object filled with liquids, shall be placed on the apparatus.
- Refer all servicing to qualified service personnel. Servicing is required when the apparatus has been damaged in any way, such as the power input terminals are damaged, liquid has been spilled or objects have fallen into the apparatus, the apparatus has been exposed to rain or moisture, does not operate normally, or has been dropped.
- Fuses shall be replaced only with the correct type and fuse value, and only when the apparatus is powered off.
- Exposure to high sound pressure levels may lead to permanent hearing loss. Take every precaution to protect your hearing.
- This product is designed specifically for use with 12 volt, negative- ground electrical systems only. Using this product in systems with positive ground and/or voltages other than 12V may result in damage to the product and your system.

## DIMENSIONS (UNIT: MM)

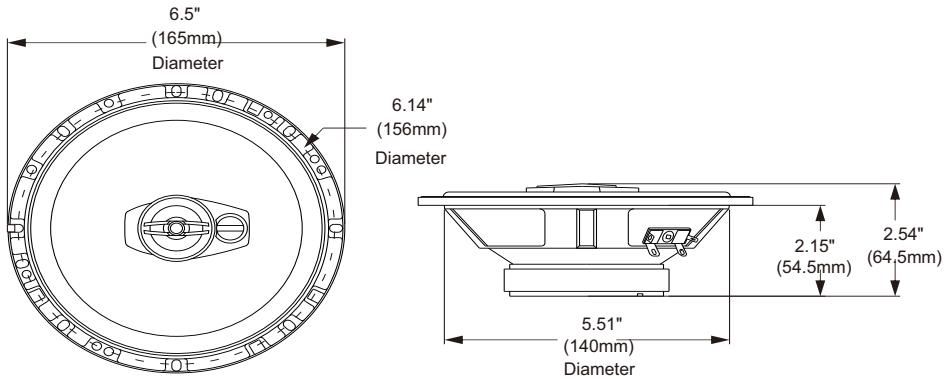

## SPECIFICATIONS

Model: FIREBALL-623	Qts	: 0.74	
Nominal Diameter	: 6.5" (165mm)	Vas	: 0.47ft3 (13.3L)
Description	: 3-Way Coaxial	Sensitivity (1W/1M):	90dB
Nominal Impedance	: 4 Ohm	Xmax	: 0.07" (1.9mm)
Frequency Response	: 52-20kHz	Mounting Diameter	: 5.51" (140mm)
Voice Coil Diameter	: 1.0" (25.4mm)	Mounting Depth	: 2.15" (54.5mm)
Power Rating (RMS/Peak):	45W / 300W	Grille/Trim Ring	: YES
Fs – Free Air Resonance	: 69 Hz	Adaptor Plate	: NO

## INSTALLATION

### OPTION : MOUNT ON THE REAR TRAY

You can mount the speakers on the rear tray of your car.

- Make sure that nothing obstructs around the mounting location of the rear tray.
- A hole for mounting may already be cut out of the inner panel of the rear tray.  
If so, you need to modify the board only.
- Ensure that the speaker terminals, frame or magnet do not interfere with any inner parts, (such as the window), etc. Also ensure that the speaker grille does not touch any inner fittings, such as the window cranks, door handles, arm rests etc.

1. Turn off the car ignition key.
  - If the power is on, the click noise generated by the connection may damage the speakers.
2. Cut out the mounting template from the packing box.
3. Paste the template on the location selected for mounting the speaker.
4. Mark the cut-off hole and the 4 bolt holes. (Fig.1)
5. Cut out the marked area and drill the bolt holes. (Fig.2)

6. Remove the grille net. (Fig.3)

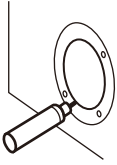

Fig.1

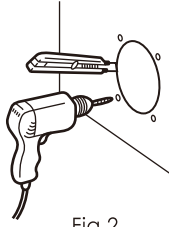

Fig.2

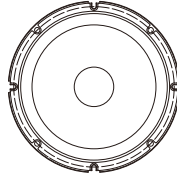
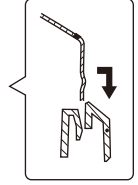

Fig.3



Follow us on:



[enigmattech.co.in](http://enigmattech.co.in)



[enigmattechnotronicx](https://www.instagram.com/enigmattechnotronicx)



[enigmadigital72](https://twitter.com/enigmadigital72)



[enigmadigitaltechno](https://www.facebook.com/enigmadigitaltechno)



[company/enigma-technotronicx](https://www.linkedin.com/company/enigma-technotronicx)

Enigma Technotronic Pvt Ltd.  
A-5, Naraina Industrial Area  
New Delhi - 110028  
E: [info@enigmattech.co.in](mailto:info@enigmattech.co.in)