

Technical features

FIREBALL-496	Class AB Amplifier
Output power RMS 4Ω ():	100 W x 4 CH
Output power RMS 2Ω ():	125 W x 4 CH
Output power (bridge) RMS 4Ω ():	250 W x 2 CH
Harmonic distortion factor (THD):	<0.15%
Frequency range(±2dB):	10Hz - 50KHz
Signal to noise ratio:	>95dB
Input sensitivity:	200mV - 6V
Fuse rating:	35A x 2
Size:	353.5 x 179 x 59.1 mm



Follow us on:



enigmatech.co.in



[enigmatechnotronix](https://www.instagram.com/enigmatechnotronix)



[enigmadigital72](https://twitter.com/enigmadigital72)



[enigmadigitaltechno](https://www.facebook.com/enigmadigitaltechno)



[company/enigma-technotronix](https://www.linkedin.com/company/enigma-technotronix)

AURA[®]

OWNER'S

MANUAL



FIREBALL-496

CAR POWER AMPLIFIER

Enigma Technotronix Pvt Ltd.



PLEASE READ CAREFULLY BEFORE USING

A-5, Naraina Industrial Area New Delhi - 110028
E: info@enigmatech.co.in



Thank you for purchasing an AURΔ amplifier. We strongly recommend using the services of a professional installation studio to install the amplifier. The correct configuration of the system and the qualifications of specialists will allow you to maximize the potential of your amplifier, avoid unpleasant situations, as well as eliminate connection errors and possible malfunctions.

Connection Recommendations

Each channel of your amplifier is rated to load from 2Ω to 4Ω when connected in stereo. When using bridged mode, the minimum load impedance should be 3Ω for subwoofer and 4Ω for full range speakers. Operating with a low load impedance will not damage the amplifier, but the device will likely overheat, causing the thermal protection circuit to shut down the amplifier. When the cooling radiator cools down, normal operation will resume. Long-term operation of the amplifier under these conditions is highly discouraged and will shorten its service life.

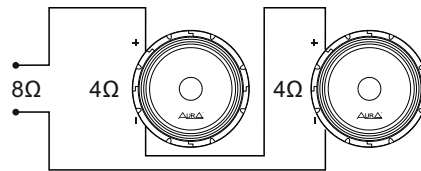

Serial connection

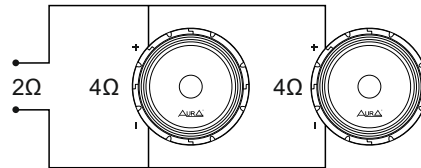

Parallel connection

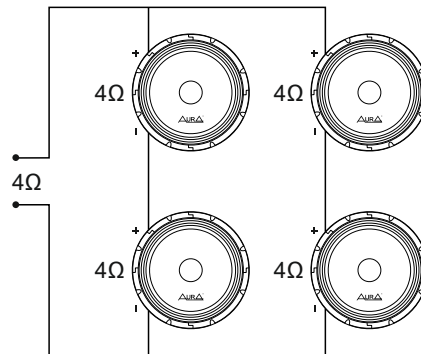

Serial-parallel connection

Most car speakers are manufactured with 4Ω impedance. When two such speakers are connected in parallel, we will get an impedance of 2Ω, which is not recommended for bridging your amplifier.

Symptoms	Possible problem	Recommendations
Distorted signal	Defective speaker system	Check the functionality and connection of the speakers. Repair or replace them.
	Insufficient supply voltage of the amplifier. Should not be less than 11.3V	Check the voltage at the power terminals of the amplifier. Check if the connection is correct and secure.
	Incorrect settings and settings of the amplifier filters	Change the crossover settings until you achieve the sound you want.
Not enough bass / treble	The polarity is reversed when the speakers are connected.	Check polarity and reconnect if necessary.
	Incorrect settings and settings of the amplifier filters	Change the crossover settings until you achieve the sound you want.
Battery fuse blows	Short circuit in the power wire or incorrect connection	Check the power cable connections and correct if necessary.
	Fuse less than necessary.	Replace with the correct fuse.
Amplifier fuse blows	The speaker impedance is too low.	Check the impedance of the speakers. It should not be less than 2Ω in stereo or 4Ω in bridged mode.
	Too much current	Check the impedance of the speakers. It should not be less than 2Ω in stereo or 4Ω in bridged mode. Install the correct fuse.
	The fuse on the amplifier is smaller than required.	Check the power cable connections and correct if necessary. Install the correct fuse.



Simptoms	Possible problem	Recomendations
Does not turn on no sound	Too weak or no signal from the control wire	Check the voltage at the output of the control wire
	Fuse blown	Check the connection of the power cables, polarity, replace the fuse
	Power cables are not connected.	Check the power cable connections and correct if necessary.
	Audio input is not connected, there is no signal from the head unit.	Check signal cables and connections, replace if necessary.
Sound on and off	Speaker cables not connected	Check speaker cable connections and correct if necessary.
	Defective speaker system	Check your speakers and repair or replace them.
	Thermal protection turns on when the radiator heats up over 90 °C	Make sure there is sufficient ventilation to cool the amplifier.
Output distortion	Loose or poor connections at the amplifier/source input/output connectors.	Check signal cables and connections, replace if necessary.
	High sensitivity of the input level. Exceeding the maximum output power of the amplifier	Adjust the input level so that there is no distortion.
	The speaker impedance is too low.	Check the impedance of the speakers. It should not be less than 2Ω in stereo mode and not less than 4Ω in bridged mode.
	The speaker terminals or cables are shorted to vehicle ground.	Check the integrity and connection of the loudspeaker connections if necessary.
	Speaker cables are not properly connected to the amplifier	Check if the speaker cables are connected properly and correct if necessary.

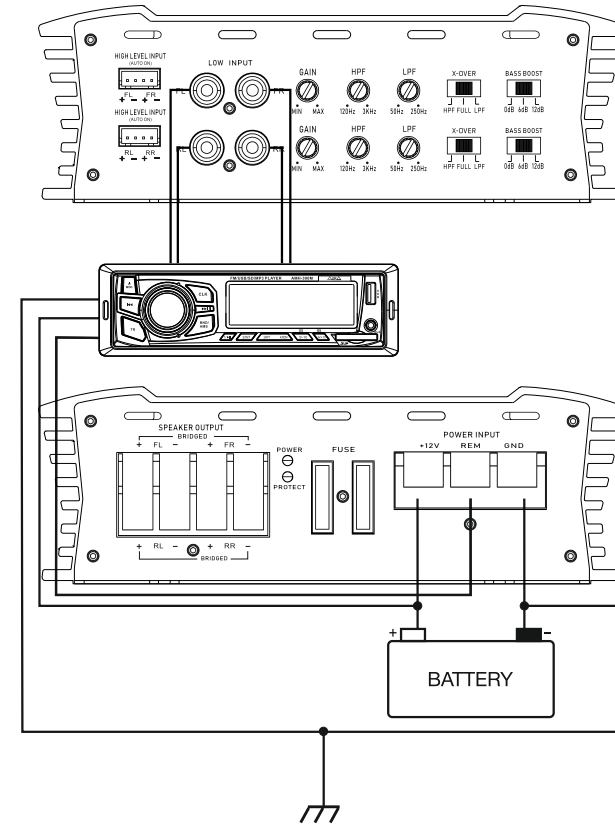

Connection Recommendations

Connect the positive (+ 12V) cable only after all other cables have been connected. The negative cable must be connected to the vehicle body exclusively by bolting. The connection point must be free of paint and reliably protected from corrosion. Loose power connections can cause unstable operation and damage to the amplifier.

The device turns on when + 12V is applied to the “REM” terminal. This terminal is low-current and does not require connection with a cable of the same cross-section as positive or negative. An acceptable wire is 18-16AWG (0.75-1.5mm²). The standard color of the control cable is blue.

Be sure to use a fuse on the positive power cable that is at least the same as the fuse on the amplifier. Install the fuse as close to the car battery as possible, but no further than 40cm from the positive terminal.

When operating the amplifier at maximum output power, it is recommended to use at least 8AWG (8mm²) cables. The cross section of the positive and negative cables must be the same. For this, the models of power cables  PCC-508R / B, PCS-308R / B are suitable.

System 1 4 channel stereo mode

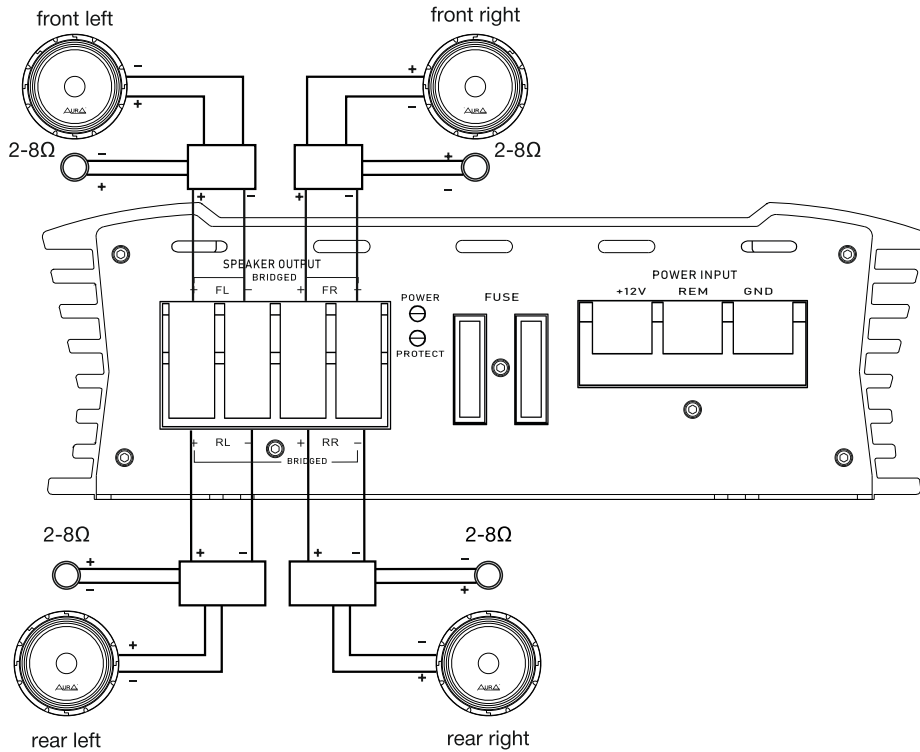
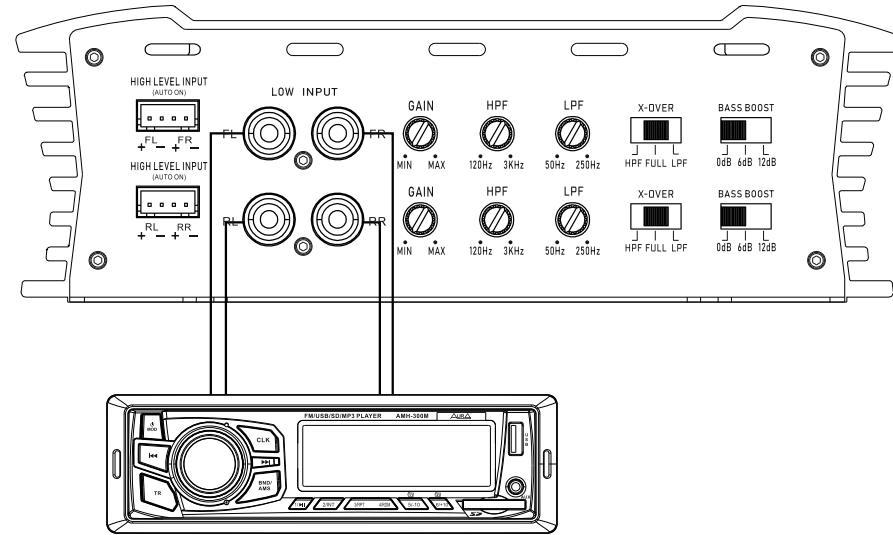

System 2 3 channel stereo/mono mode

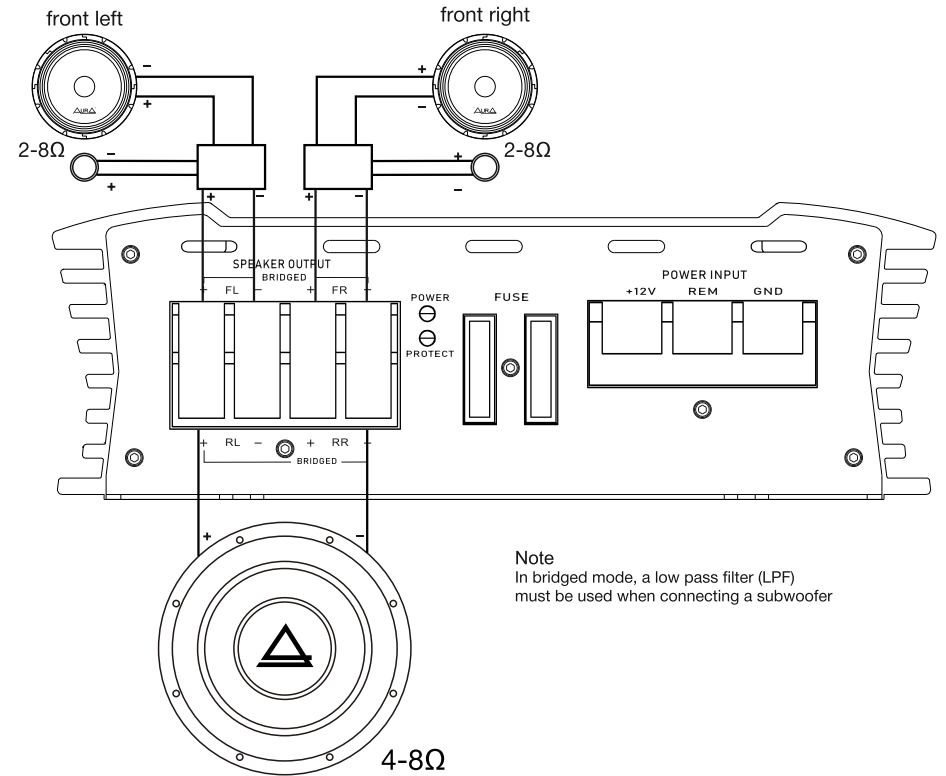
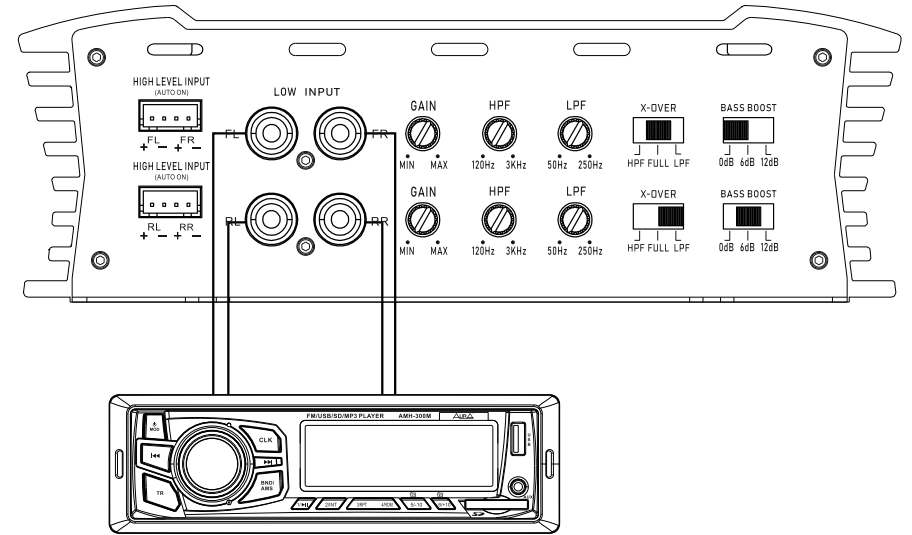

Note
In bridged mode, a low pass filter (LPF)
must be used when connecting a subwoofer